

# Hydraulic Adapter Sleeves

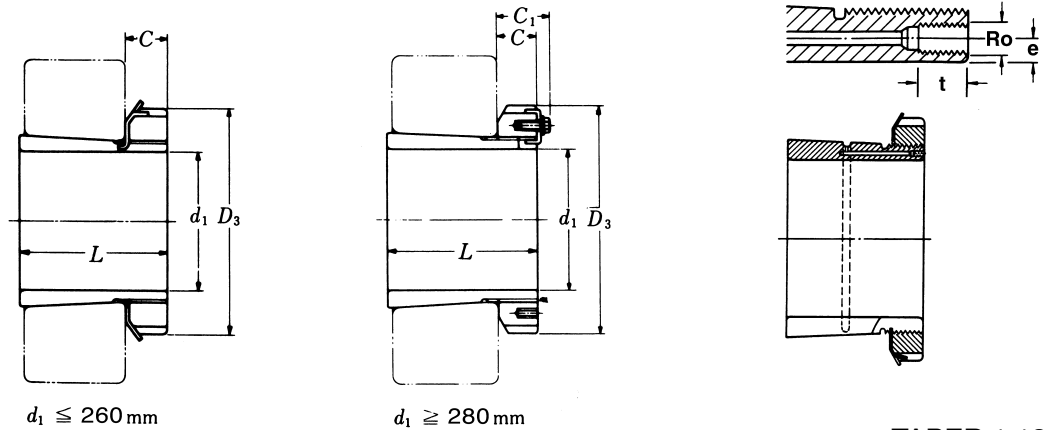

## HOH 31

TAPER 1:12

Hydraulic Adapter <sup>1)</sup> Part No.	d <sub>1</sub> H mm	L mm	D <sub>3</sub> mm	C mm	C <sub>1</sub> <sup>2)</sup> mm	R <sub>o</sub>	e mm	t mm	Lock Nut	Lock Washer and Lock plate	Weight (kgs)
HOH 3132	140	119	210	28	—	M6	4.2	8	AN 32	AW 32	7.670
HOH 3134	150	122	220	29	—	M6	4.2	8	AN 34	AW 34	8.380
HOH 3136	160	131	230	30	—	M6	4.2	8	AN 36	AW 36	9.500
HOH 3138	170	141	240	31	—	M6	4.2	8	AN 38	AW 38	10.800
HOH 3140	180	150	250	32	—	M6	4.2	8	AN 40	AW 40	12.100
HOH 3144	200	161	280	35	—	M6	4.2	8	HN 44	AW 44	15.500
HOH 3148	220	172	300	37	—	M6	4.2	8	HN 48	AW 48	18.300
HOH 3152	240	190	330	38	—	M6	4.2	8	HN 52	AW 52	23.200
HOH 3156	260	195	350	39	—	M6	4.2	8	HN 56	AW 56	25.900
HOH 3160	280	208	380	40	53	M6	4.2	8	AN 60	AL 60	30.200
HOH 3164	300	226	400	42	56	M6	3.5	8	AN 64	AL 64	34.900
HOH 3168	320	254	440	55	72	M6	3.5	8	AN 68	AL 68	49.500
HOH 3172	340	259	460	58	75	M6	3.5	8	AN 72	AL 72	54.200
HOH 3176	360	264	490	60	77	M6	3.5	8	AN 76	AL 76	61.700
HOH 3180	380	272	520	62	82	M6	3.5	8	AN 80	AL 80	70.600
HOH 3184	400	304	540	70	90	M6	3.5	8	AN 84	AL 84	84.200
HOH 3188	410	307	560	70	90	M8	6.5	12	AN 88	AL 88	104.000
HOH 3192	430	326	580	75	95	M8	6.5	12	AN 92	AL 92	116.000
HOH 3196	450	335	620	75	95	M8	6.5	12	AN 96	AL 96	133.000
HOH 31/500	470	356	630	80	100	M8	6.5	12	AN 100	AL 100	143.000

Note :

- 1) Hydraulic adapter sleeves are supplied complete with lock nuts and lock washers or lock plates °  
整組油壓緊定套附螺母及華司或鎖定片。
- 2) Adapter with the dimension C1 have a locking device as shown in the right illustration °  
標示出 C1 尺寸的套筒附鎖定裝置, 如右圖所示。